

## GPS Guidance Systems – An overview of the components and options

Matthew Sullivan-Extension Program Specialist  
M. Reza Ehsani-Assistant Professor

The Ohio State University Extension  
590 Woody Hayes Drive  
Columbus, OH 43210

As precision agriculture increases in popularity and availability, the use of guidance systems is increasing as well. Producers have several options to successfully apply crop protection products, like fertilizers or lime. Some applicators follow corn stalk rows, while others rely on experience. For several years, foam marker guidance has been the standard by which accurate application of products were applied. The need arose for a more accurate and less stressful way of applying inputs. A more effective way of performing these tasks is using a GPS guidance system. Guidance systems are defined by the use of a DGPS receiver system and a guidance mechanism, which could be it a set of lights, visual screen or audible tones.

### **Components of a guidance system**

The basic components of a guidance system are shown in Figure 1. The main components needed for a guidance system are a DGPS receiver, antenna, controller and guidance display along with the accompanying wiring harness. Other optional items may include a data logger, sound device or visual display.

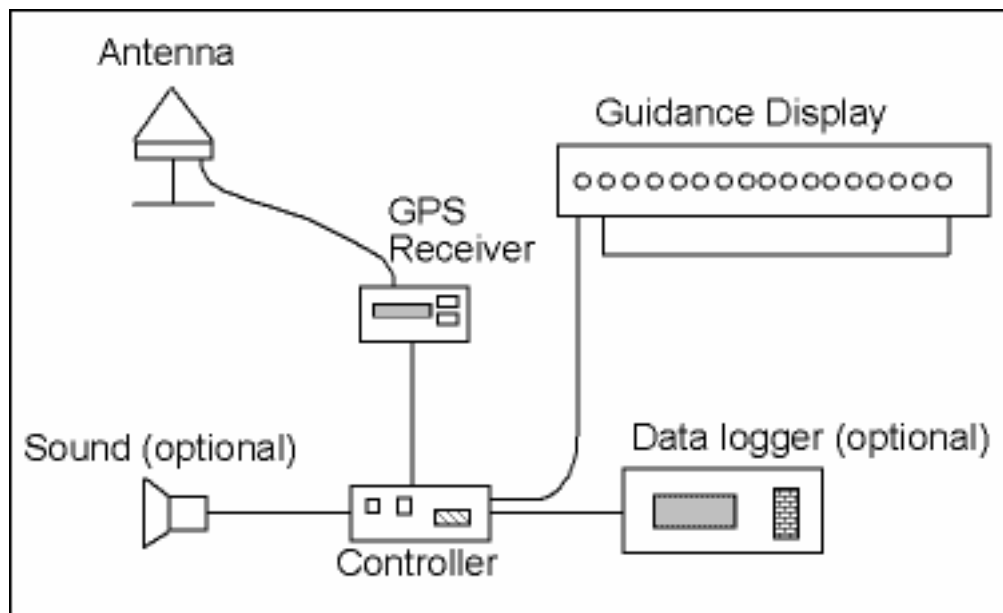

Figure 1. Components of a guidance system.

The GPS antenna is used to collect the GPS signals. The antennas pictured are waterproof or water resistant and have magnetic mounts (Figure 2). The location of the antenna may be an important aspect to the performance of the guidance system. The antenna should be placed on the vehicle with complete visibility to all angles of the sky. Most antennas are placed on top of the cab of the tractor or applicator. See the manufacturer's recommendations on the correct location position of the antenna.

The GPS receiver determines the location information and sends that information to the guidance system to create an accurate navigation path. The DGPS receiver has several options available for a source of differential correction signal, Wide-Area Augmentation Systems (WAAS), Coast Guard, or subscription L-Band signals or a combination of signal options. Some of the GPS receivers have the option to change from one signal type to another on the menu board, where others need to be changed from a software program. Some receivers will just have one signal option available. When choosing a GPS receiver, be sure to select the receiver that will provide the signal choices that will give the most available and accurate signal for your region of the country. This information can be found from the Federal Aviation Administration, U.S. Coast Guard or subscription service providers.

Most of the guidance systems are capable of using any type of GPS receiver that meets the guidance system specification. If a GPS receiver was purchased before the guidance system, investigate the compatibility between the receiver and guidance system.

Some guidance systems have integrated the antenna and GPS receiver in one unit. This type of integration is increasing with the ability to make components smaller. This integration reduces the number of components in the cab and streamlines the set-up procedures.

GPS receiver update rate is the number of times a GPS receiver sends the position information per second. An update rate of 1 Hz will send out the position information once every second, a 5 Hz GPS receiver will send out the position information five times per second. Most guidance systems need an update rate of 5 Hz to operate effectively. A GPS receiver with an update rate of 1 Hz may not provide enough data to operate a guidance system effectively due to the speed of information being processed.



Figure 2. GPS antennas and receivers.

The choice of a guidance system display will depend upon producer preference. The display comes in several different types such as a light bar, moving lines or a visual picture of current application direction (Figure 3). All types of systems provide a means of directing the applicator to stay on a desired path.



Figure 3. Light bar and Visual display

The controller is used to select menu options in the guidance system. Along with the controller, a data logger, visual display or sound device can be an important attribute to a guidance system for custom applicators or producers that need to document when and where a product was applied. Some of the systems have a visual screen along with the data logger to provide a visual representation where the material was applied (Figure 4). Some data loggers can also mark field attributes such as rocks and drainage areas, or save them for future reference. The controller and data logger may be combined into one unit or two separate pieces of equipment. The data logger may also have a visual display. A sound device may inform the user where to steer, where product was applied, or hazards located in the field.



Figure 4. Controller and Data logger

### **Guidance features and options**

When deciding on what system to evaluate, consider several options and features. Products are being updated often, so check with the manufacturer for the latest updates and new features.

### **Patterns (tracking)**

Pre-set patterns show how a guidance system can be used during field operations. The two most popular patterns for ground application are parallel swathing (A-B line) and contour (Figure 5). The parallel swathing choice enables the applicator to follow a

predetermined swath width across the entire field. The A-B line is determined on the first straight pass and then the remaining passes are stored in the memory of the guidance system. The contour selection enables the applicator to make an initial pass around the outside edge of a field. The guidance system will save the information on that pass and then guide the applicator around the field for consecutive passes. Some guidance systems will combine the parallel and contour options together, where the A-B line and contour guidance can be selected simultaneously. Usually, the contour option is only performed around the edge of the field. The contour pattern is not recommended for parallel tracking. The contour points are saved from the last pass, so if a driving error occurs from the previous pass, the error will be magnified in each consecutive pass. Other tracking options are available depending on the specific need; some of the other options are pivot (for center pivot irrigation systems), racetrack or spiral.

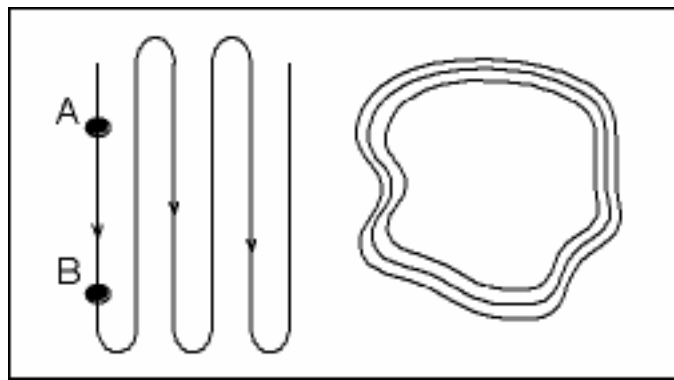

Figure 5. Parallel (left) and Contour (right) swathing options.

### **Menu selections**

All of the guidance systems have some type of menu selection for setting up the guidance system and/or GPS receiver. The menu selection can vary in the amount of options depending upon the need of the applicator and the ability of the guidance system to perform different applications.

### **Real-time text information**

The guidance systems provide some type of real-time text information. The information may vary depending upon the system. Most of the guidance systems will provide a numeric display error. This number will provide the driver an additional way of determining how far away they are from the desired path. This numeric display error can be a beneficial attribute when turning into the next pass. Other options may be heading error, ground speed, swath # or area applied.

### **Area calculation**

Another feature that may be important to users of a guidance system is the calculation of field and application areas. Correct acreage is useful in determining the correct amount of nutrients and crop protection products along with having accurate yield records. The guidance system can also be connected to a sprayer controller and when the

sprayer is turned on, the mapping portion of the guidance system will be turned on as well. This option provides an accurate measure of an area applied.

### **Return to point feature**

This feature allows the user to mark the location of the field and return back to that location by using the guidance system. The term implies that it places a “stake or marker” in the field and the guidance system can direct the user back to that point.

### **Heading or “Look-ahead” feature**

This option on the guidance systems helps the user know a forward-looking direction. Usually the guidance systems will “look-ahead” a certain amount of time and tell the user which direction they need to go or the direction where they are heading. Depending on the system, the user may set this amount of time or sensitivity of the “look-ahead” feature. This feature goes by many different names and styles.

### **Tilt and hill correction**

This correction feature can be used with some guidance systems that have the capability to detect when a field is not level. The position error is corrected when the machine is going over uneven ground. If the ground is uneven, the antenna position and the center of the machine are not in the same location. The error between the antenna position and center of machine will create an error in the swath width. This error could provide gaps or overlap in the application of material.

The above options describe above are an overview of what is needed for guidance system operation. Other options are available depending on how the system is built. Continue to check with the manufacturer and distributors of the systems for updates.

GPS Guidance systems are one of the quickest ways to utilize precision agriculture to the fullest. The systems are easy to operate and can be used in several different applications. As the accuracy increases along with the technology, there will be opportunities to use these systems for more precise applications in the agricultural community.

All educational programs conducted by Ohio State University Extension are available to clientele on a nondiscriminatory basis without regard to race, color, creed, religion, sexual orientation, national origin, gender, age, disability or Vietnam-era veteran status.

Keith L. Smith, Associate Vice President for Ag. Adm. and Director, OSU Extension.